

A BLUEPRINT FOR SUCCESS:

THE RENAISSANCE OF

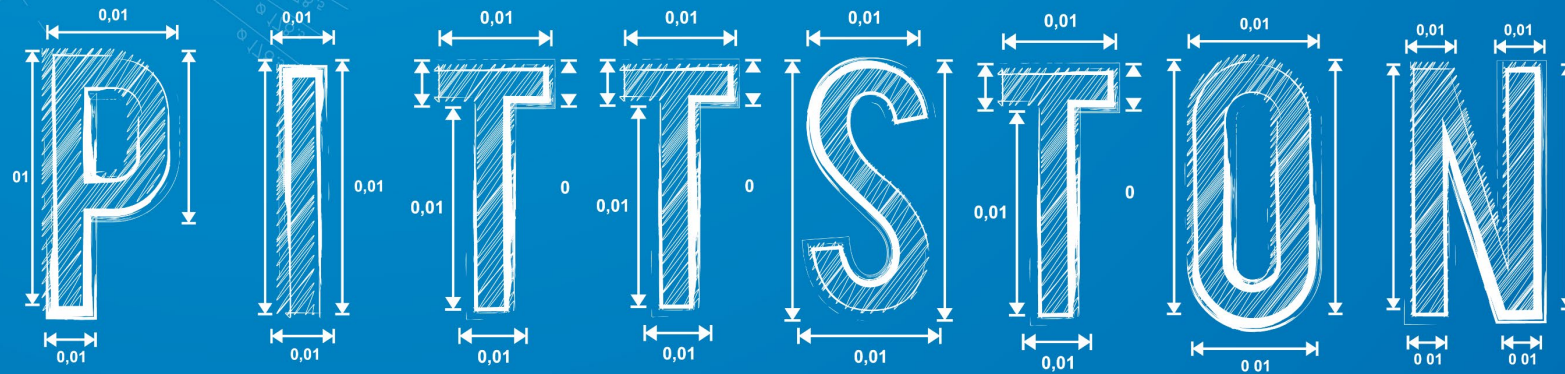



**DOING THE SAME THING OVER AND
EXPECTING DIFFERENT RESULTS.**

The background is a technical drawing on a blue grid. It features various geometric shapes and dimensions. In the top left, there's a 45-degree angle and a diameter of 4.5. A horizontal dimension of 114.6 is shown. In the center, there are three stacked diameters of 178.5. On the left, a circular feature has a diameter of 4.5 and a distance of 3.2 from the center. At the bottom, there's a dimension of 15.5. The drawing includes various lines, circles, and rectangles, representing a complex mechanical or structural design.



**DOING THE SAME THING OVER
AND EXPECTING THE SAME RESULTS.**

The background is a technical drawing on a blue grid. It features various geometric shapes and dimensions: a 45-degree angle, a diameter of 4.5, a length of 114.6, a diameter of 178.5, a length of 3.2, a diameter of 4.5, a length of 15.5, and a length of 5.7. The drawing includes lines, circles, and rectangles, representing a complex mechanical or structural design.

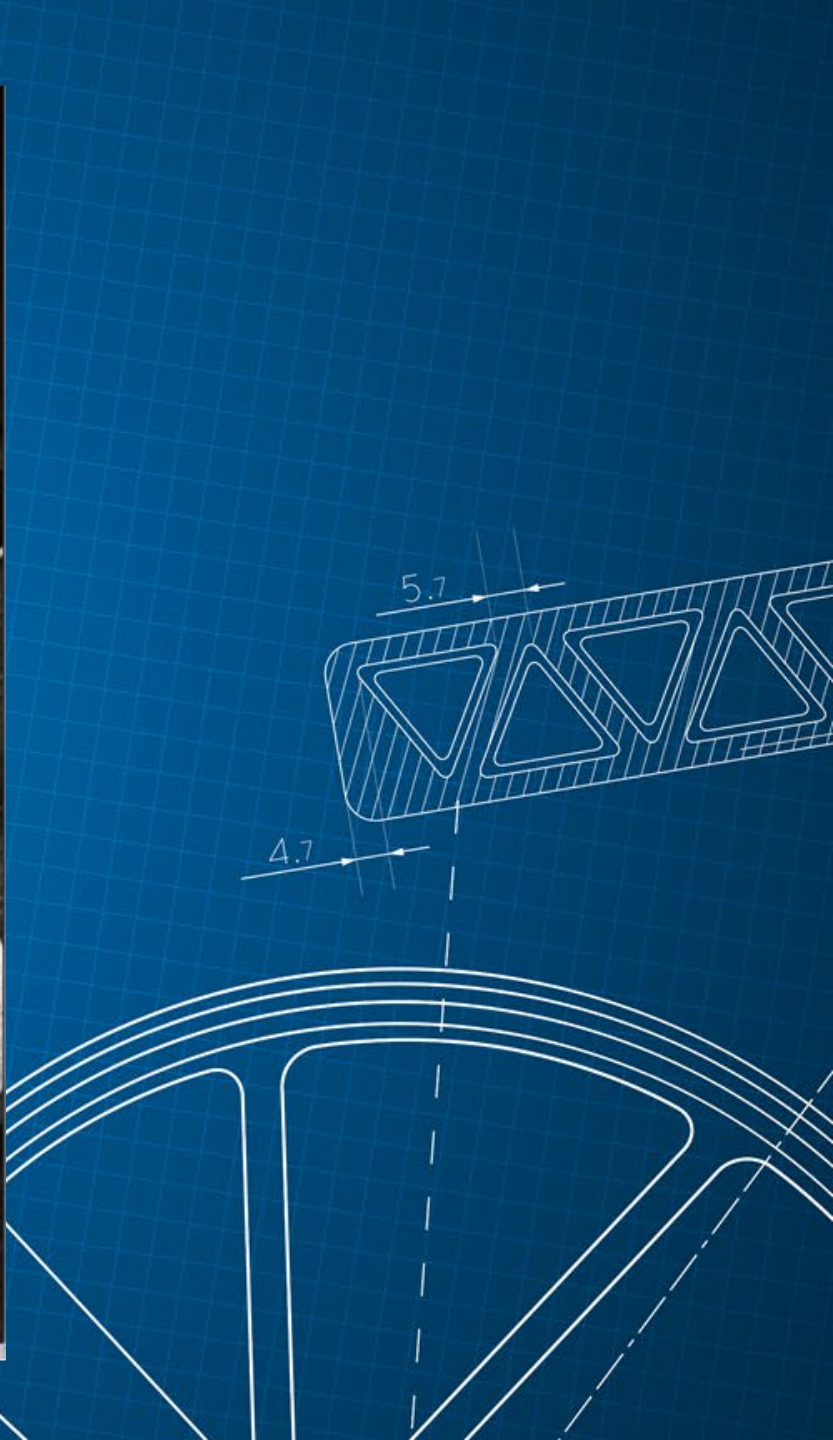
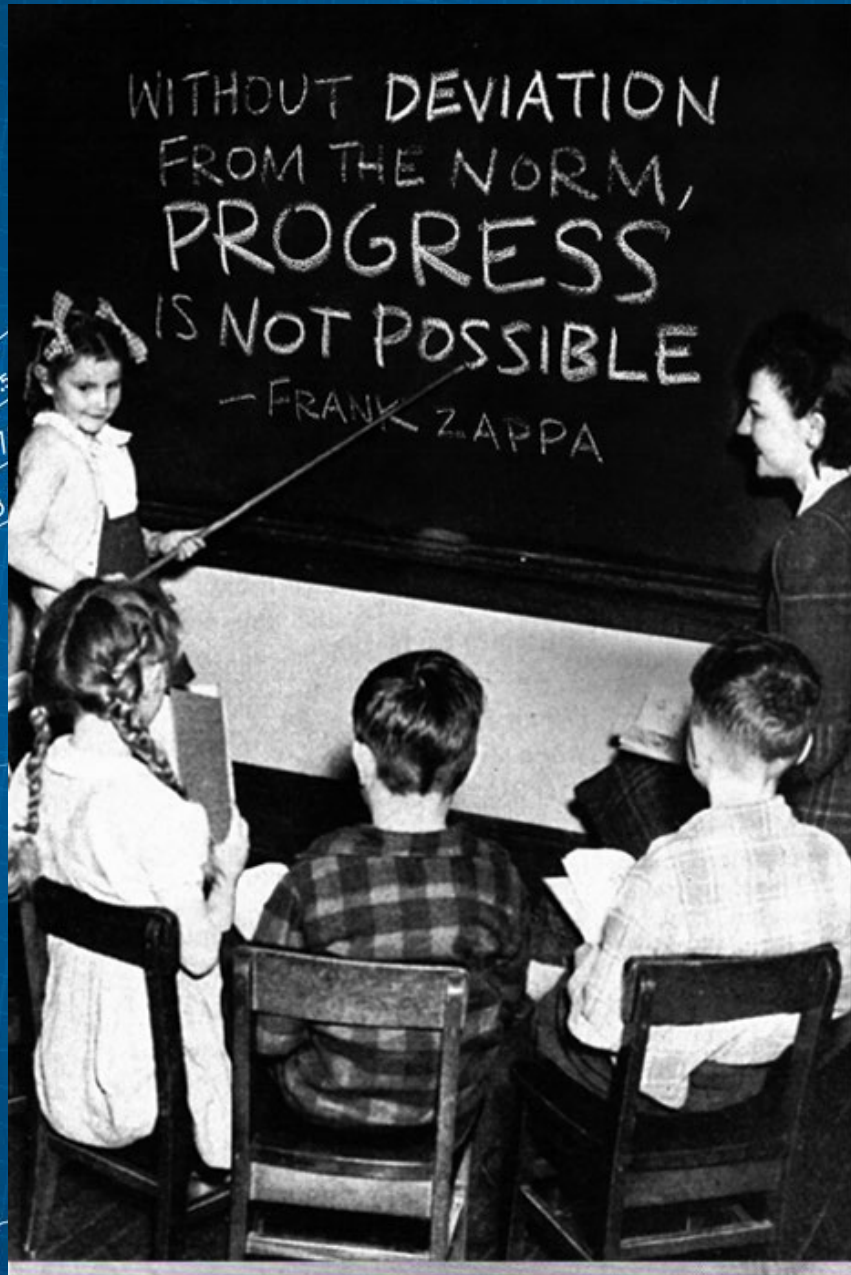
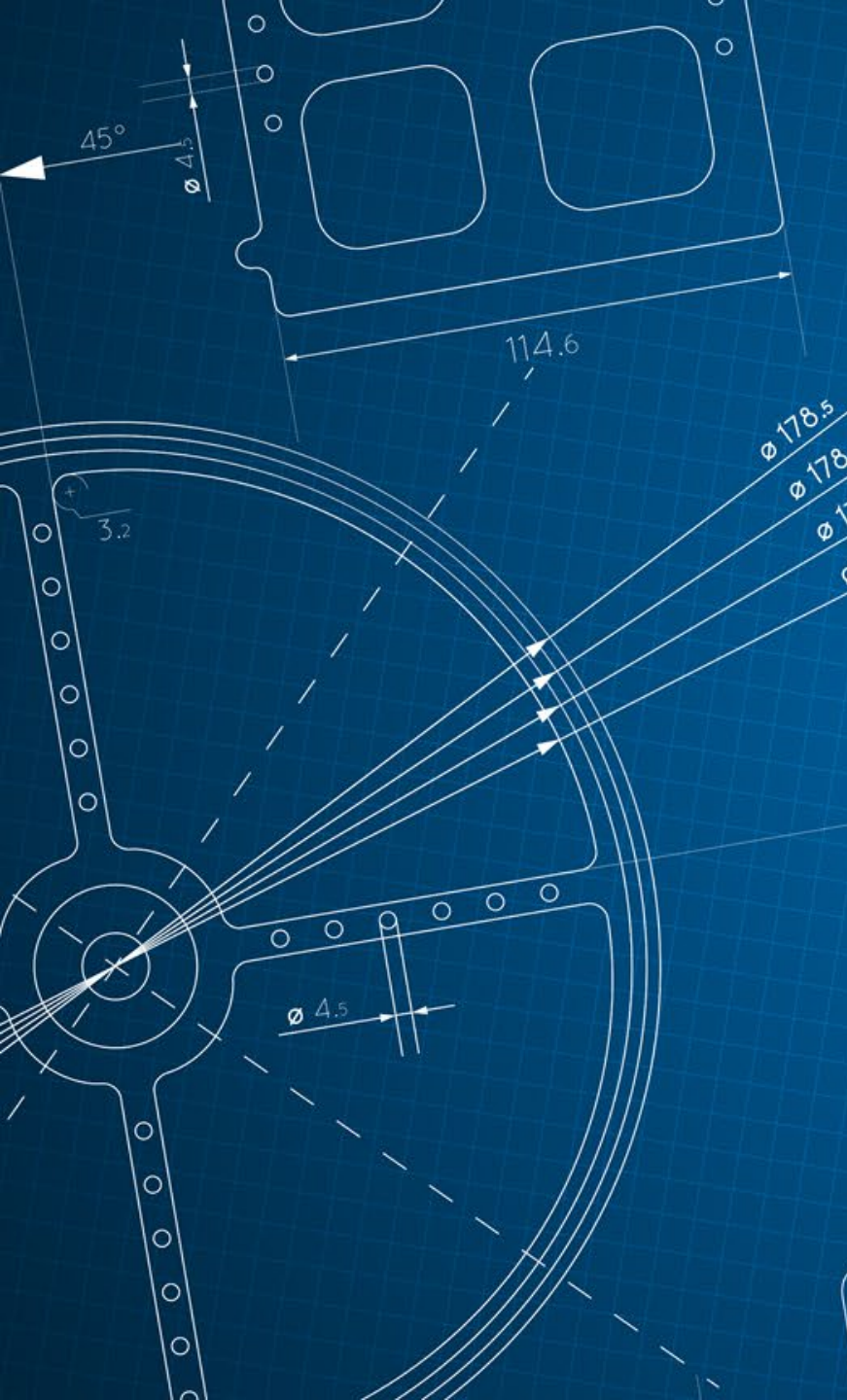

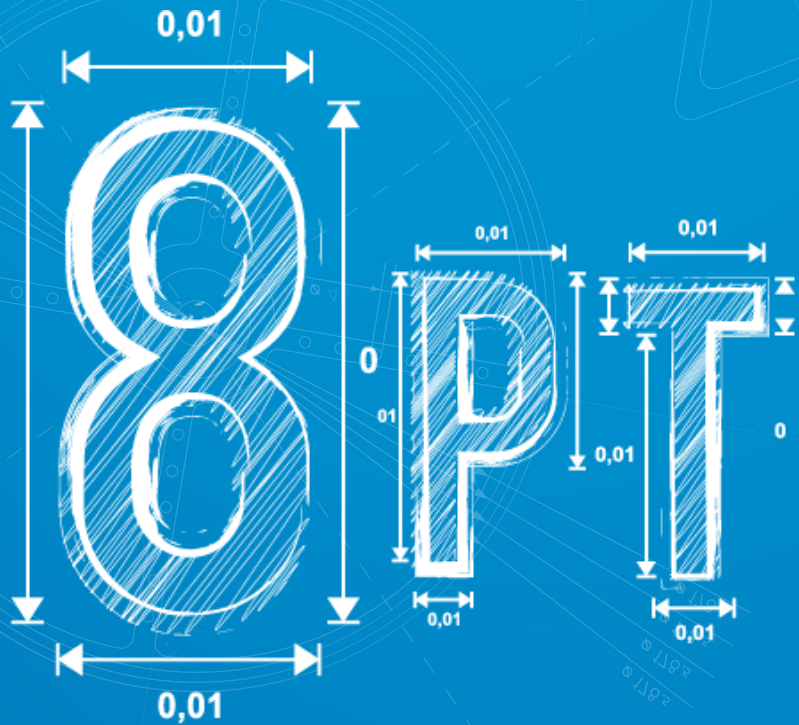

PLAN

1. DOWNTOWN DEVELOPMENT

2. NEIGHBORHOOD STABILIZATION AND DEVELOPMENT – BLIGHT REMEDIATION

3. INFRASTRUCTURE IMPROVEMENT

4. OPERATIONS RESTRUCTURING

5. ART/PROGRAMMING IN PARKS & PUBLIC FACILITIES

6. PRIORITIZING AND EXPANDING CODE ENFORCEMENT/SAFETY

7. ASSESSMENT EVALUATION SHORT VS. LONG TERM PLANS

8. MUNICIPAL COOPERATION



City of Pittston

neighborhood housing initiative

1. Historical Analysis
2. Current Conditions
 - a. Downtown and Neighborhoods
3. Identify Problems
4. Development Plan
 - a. Inventory, Evaluation and Data
 - b. Mitigation Strategies
 - c. Housing Summit = Shareholders and Partners
 - d. Public Presentation
5. Implementation
6. Anticipated Outcomes
7. Impact

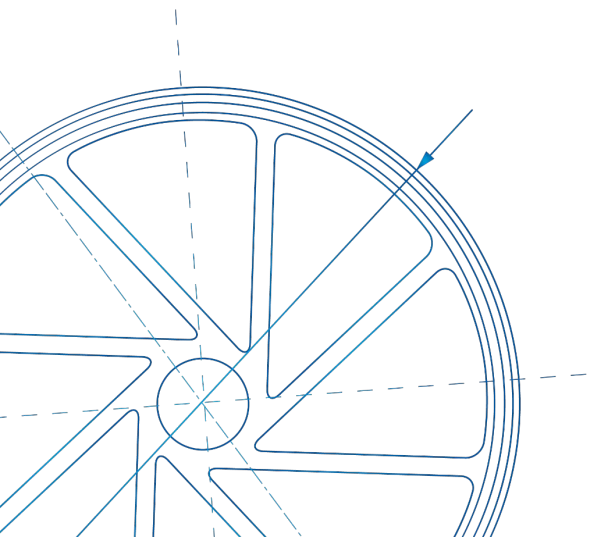

WHAT IS BLIGHT?

Blight encompasses vacant lots, abandoned buildings and houses in derelict or dangerous shape. Environmental contamination can be included as blight. Blight can refer to smaller property nuisances including overgrown lawns, uncollected litter, graffiti, inadequate street lighting and a general lack of concern for appearance to a structure or neighborhood element.

Pennsylvania enacted "Blighted Property" via the enactment of Act 79 of 2019





STRATEGY

DEMOLITION



REHABILITATION



INFILL



BUILD COMMUNITY



PREVENTION



LEGISLATION & ADVOCACY





BLIGHTED PROPERTY BOARD
CITY OF PITTSTON

STRATEGY + INFORMATION

PITTSTON CITY COMMUNITY COOKOUT

JOIN US!

WEST PARK
12pm-2pm

SEPT.
25TH

The City of Pittston is happy to present it's second neighborhood social event! Join us in West Park on September 25th for food, refreshments, music, games and entertainment! Activities will be provided for the kids! Bring your own chair or blanket, and get ready for some summer fun!

www.cityofpittston.org | 570.654.4601

www.cityofpittston.org 570.654.4601

www.cityofpittston.org 570.654.4601

ICED.
n, the Office of
vntown Pittston
ank you for your
surrounding
ken time to create
asn't gone
on, we would
enjoy and keep

el Lombardo
cityofpittston.org

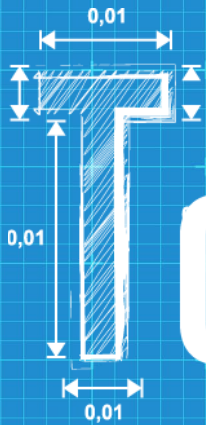

OMATO BAR



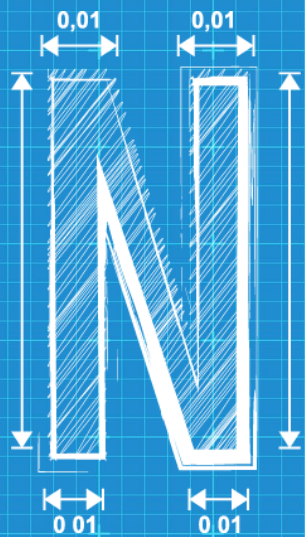

NEWROSE BUILDING

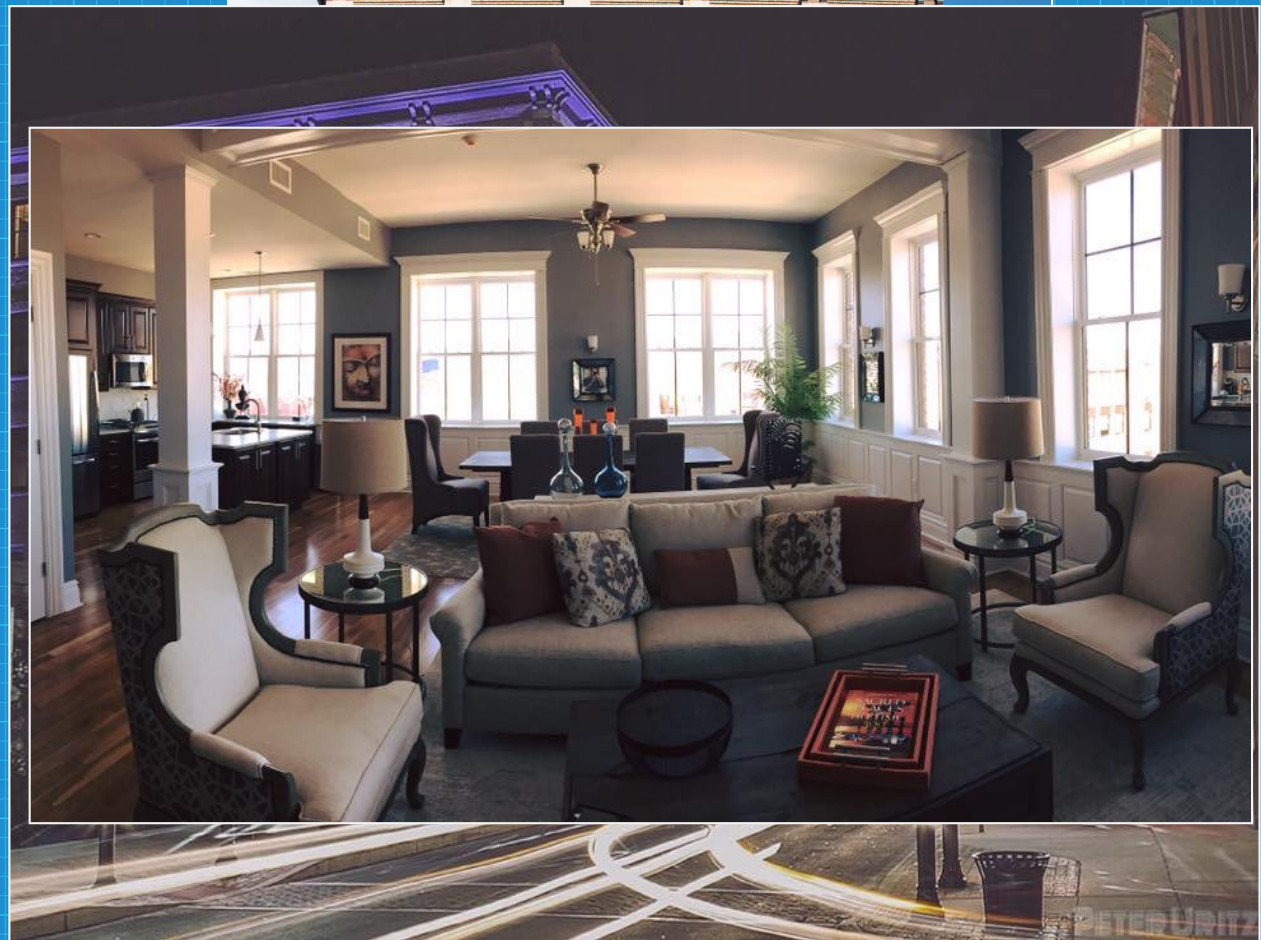

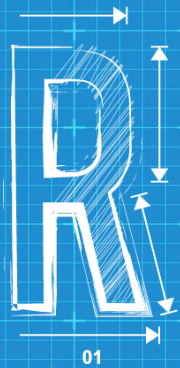

RIVERFRONT



CONDOMINIUMS



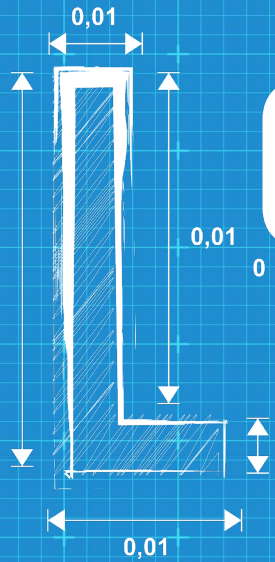

OFTS
@23

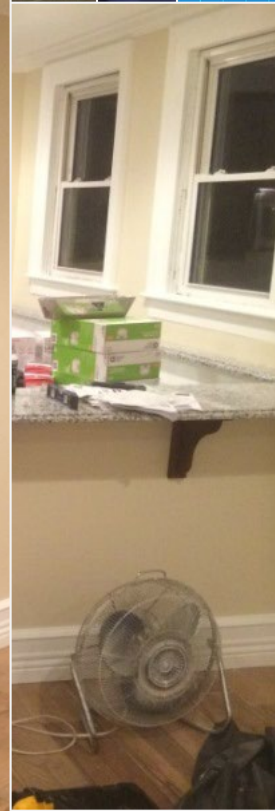

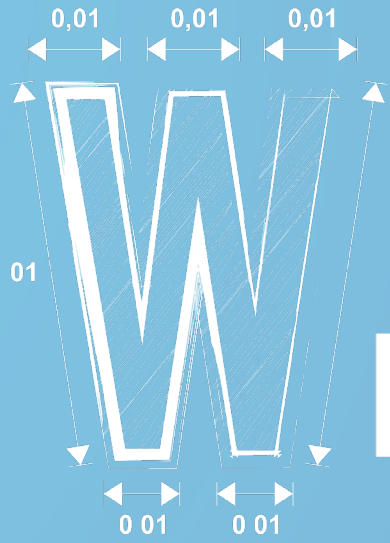

HAT GETS
MEASURED

GETS DONE....

CASE STUDIES



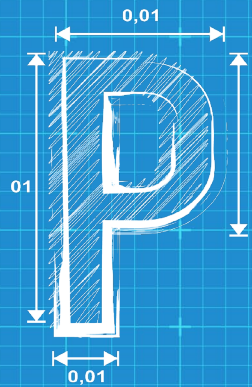

PITTSTON



GATEWAY

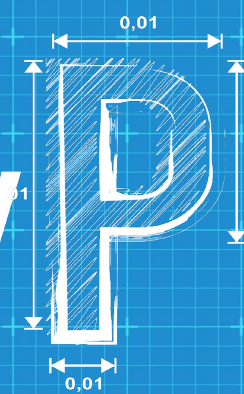

PROJECT



**SOUTH MAIN STREET
PHASE 1**

9 PROPERTIES

**COMBINED CITY TAXES
\$3,900**

283 + 289-291 S MAIN STREET



USED TIRE BUSINESS



**CONDEMNED DOUBLE-BLOCK
HOUSE**

293 + 295 S MAIN STREET



BOARDING HOUSE



**VACANT LOT/
DILAPIDATED GARAGE**

299-301 + 303 + 307 S MAIN STREET



VACANT HOUSE

**VACANT
LOT**



BLIGHTED RENTAL PROPERTY

PAD SITE 1 LUZERNE BANK PROJECT COST \$1,600,000



PAD SITE 2 ENTRANCE DOLLAR GENERAL PROJECT COST \$1,900,000



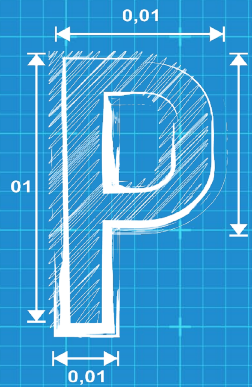

PITTSTON



GATEWAY

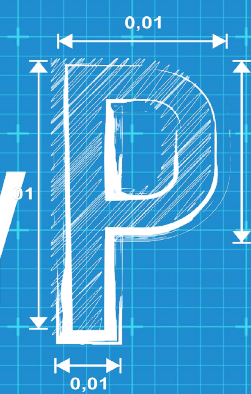

PROJECT

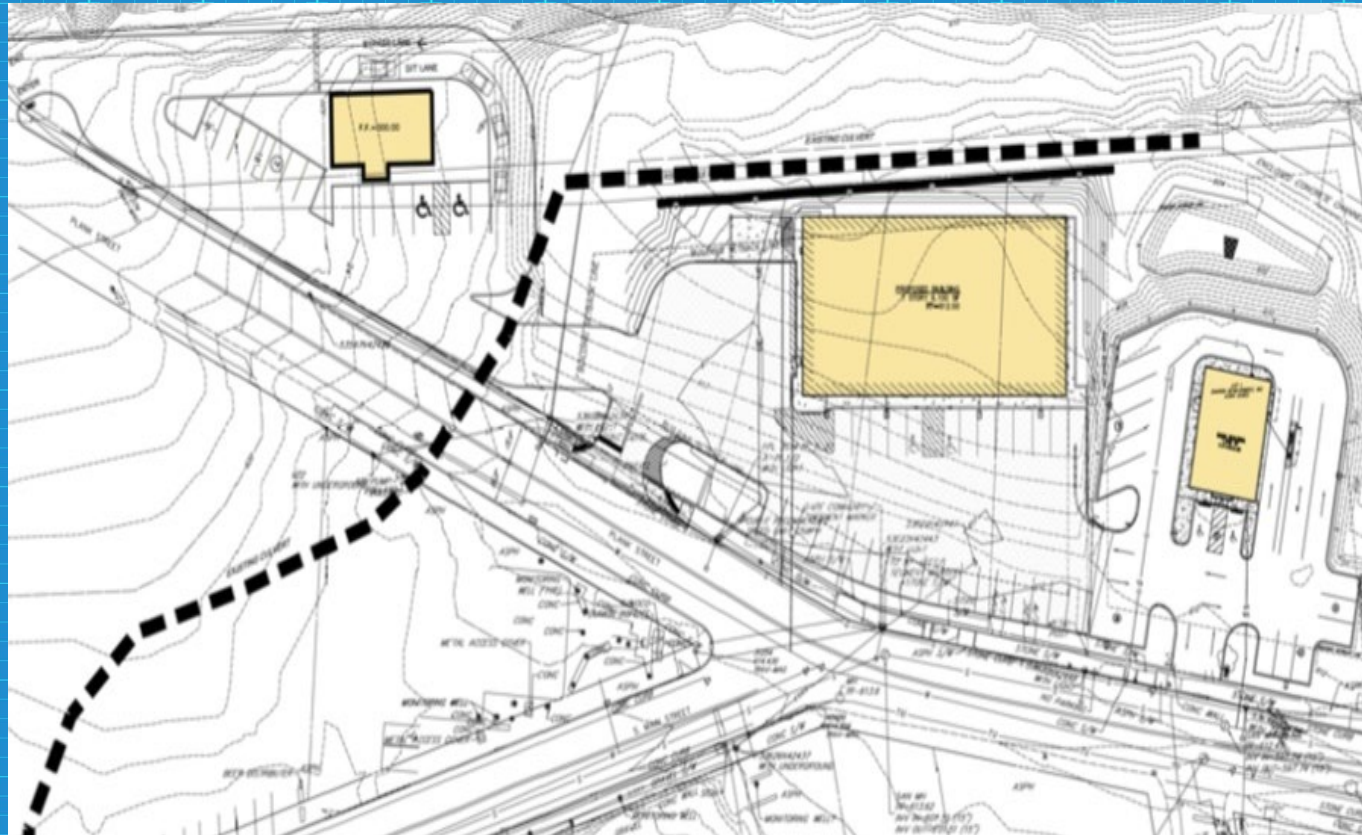

**SOUTH MAIN STREET
PHASE 2
PAD SITE 3**

**FUTURE DEVELOPMENT
\$1,200,00 FAST FOOD**

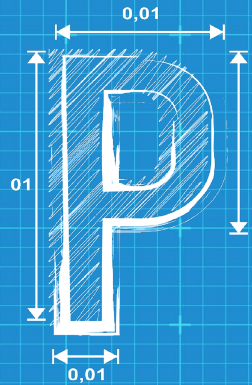

ITTSTON



ATEWAY

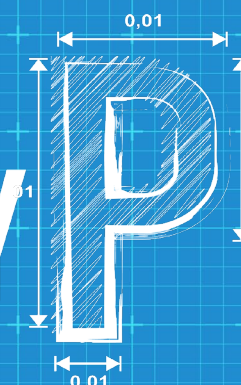

PROJECT

SOUTH MAIN STREET

- Prior to Gateway Project Phase 1
 - 9 Properties (7 Structures, 2 Lots) Combines City Taxes= \$3,900
- Upon Completion of Phase 1 of Gateway Project: 2 Pad Sites
 - overall improvements = \$3,500,000
 - city tax revenue \$11,345
- Phase 2: 1 Pad Site
 - Estimated project = \$1,200,000
 - City tax revenue = \$3,500

Total Estimated Annual Tax Gain= \$10,945

*County and School District also realized tax gains

FUNDING
YOUR
DEVELOPMENT

The image features a technical drawing of the word "FUNDING" in a serif font, overlaid with various dimension lines and numerical values such as "0,01". A central dark blue circle contains the text "FUNDING YOUR DEVELOPMENT". Six lines radiate from this central circle to six smaller circles below, each containing a funding mechanism acronym: RACP, LSA, CDBG, NAP, PFHA, and FEDERAL EARMARK.

RACP

LSA

CDBG

NAP

PFHA

**FEDERAL
EARMARK**

WHAT ARE THE RESULTS?



BLIGHT ELIMINATION

INCREASED NEW HOUSING OPPORTUNITIES

INCREASED PERMITS + DECREASE IN CODE VIOLATIONS

ABATEMENT OF ENVIRONMENTAL HAZARDS

PROPERTY TAX REDUCTION (HOMESTEAD EXEMPTION)

INCREASED BUSINESS GROWTH

CONSERVATION OF NEIGHBORHOODS

INCREASED EARNED INCOME TAX BY VOLUME

IMPROVED PUBLIC SAFETY

INVESTMENT GRADE CREDIT RATING

INCREASED PRIVATE DEVELOPMENT OPPORTUNITIES

INCREASED COMMUNITY PRIDE AND SPIRIT

GROWTH IN BELOW-AVERAGE DEMOGRAPHIC CATEGORIES

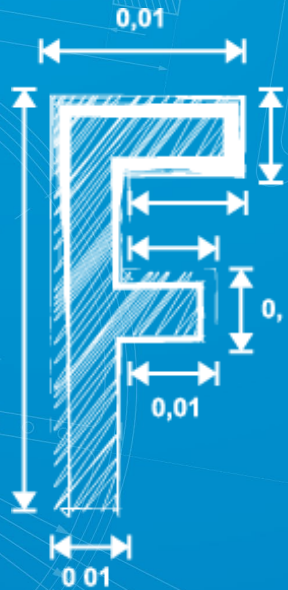

UTURE



PLANS

COOPER'S

O
-
O
P



UNDER CONSTRUCTION

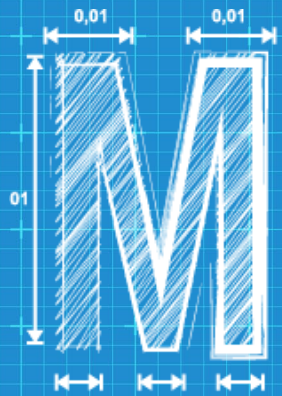

MIXED

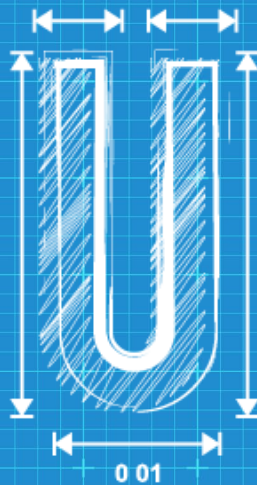

USE



UNDER CONSTRUCTION



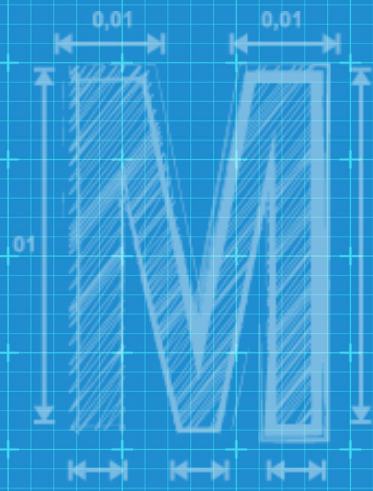

MARKET & MAIN



MARKET & MAIN
105 S. MAIN ST.
PITTSBURGH, PENNSYLVANIA



37 N. Washington St.
Wilkes-Barre, PA 18701
570.829.4200
www.quad3.com

11/14/12



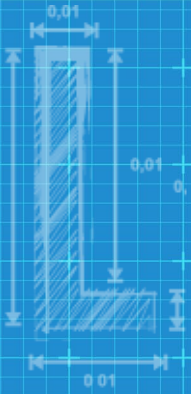

AUREL

I N E



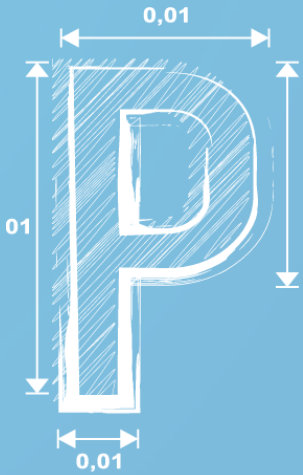

PROGRESS THROUGH PARTNERSHIP



EXCHANGING IDEAS, COLLABORATING & DEVELOPING A UNIVERSAL STRATEGY.



- Mayor Jeff Cusat, Hazelton
- Mayor Paul Roberts, Kingston Borough
- Mayor Kevin Coughlin, Nanticoke
- Mayor Jim Kenney, Philadelphia
- Mayor Michael Lombardo, Pittston
- Mayor Paige Cagnetti, Scranton
- Mayor George Brown, Wilkes-Barre
- Mayor Derek Slaughter, Williamsport

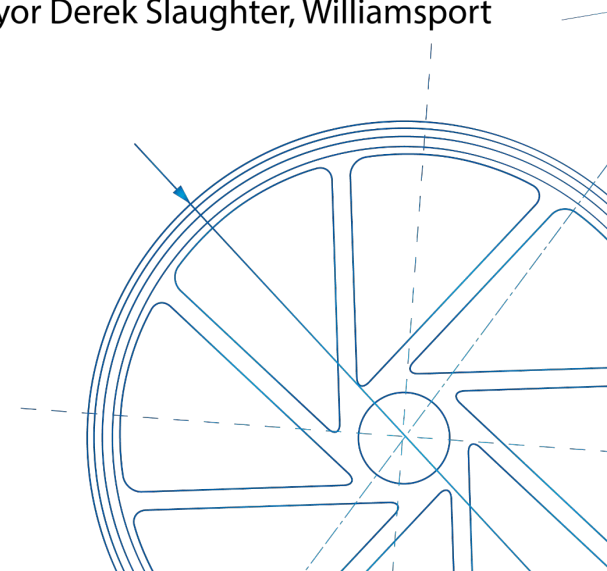



MAYORLOMBARDO@CITYOFPITTSTON.ORG

